



Genesis GX-37D
Product Presentation
Nov 1st, 2011

2011 Genesis Portfolio: Focus on GX-37D



Increase Throughput



GC-120Q
140Kcph
700 x 500mm



GC-60D
66Kcph
1016 x 508mm

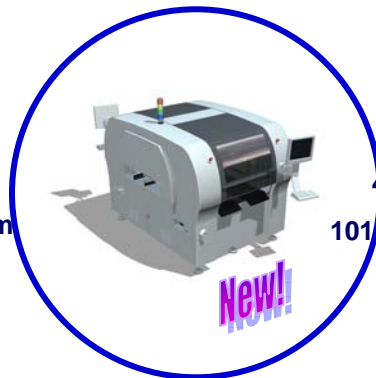

GX-37D
48Kcph
1016 x 508mm



GX11/GI14D
30Kcph
813 x 610mm



GC-30S
35Kcph
1016 x 508mm
635 x 610mm



GX-11S
16Kcph
813 x 508mm
813 x 610mm

GX-37D Value Proposition

For CEMs and OEMs... GX-37D delivers the total lowest cost of ownership

- **Save significant floor space by replacing two or more platforms**
 - Carries more components to the PCB vs any competitive solution... Fewer trips > efficiency < floor space
 - Capable of replacing multiple platforms with a single machine
- **Quote any job and achieve maximum productivity**
 - Handles complete range of components, in any package type, across a large board range in one compact footprint
 - All-in-One placer for prototyping
- **Enhance performance/extend the life of production lines**
 - Speed of a traditional turret, in 1/3rd footprint, and the flexibility to place any component
 - The perfect line balancer capable of optimizing the performance up / down-line machines
 - Replace multiple multifunction machines & manual insertion with a single GX-37D
- **Reduce Cost of Ownership**
 - Fewer machines requires less Capex, maintenance, power/air
 - Less programming, NPI, operators, and hand-assembly
 - Lower cost of quality and repair costs by automating components that were previously placed manually
- **Achieve continuous, efficient production**
 - Automated utilities to reduce machine stoppages, waste, and defects
 - Tools to quickly and confidently return to full capacity
 - NPI tools that accelerates ramp to volume and quality

Genesis GX-37D

GX-37D consists of one module, each containing two beams. The components are vision inspected and then placed on a stationary PCB. While one head is picking components, the other head is placing components for maximum machine utilization.

Series II Dual Beam High Speed Placement

- One Series II Lightning Head(rear beam)
- One Series II InLine7 Head(front beam)
- One Magellan ULC(2.3m/p or .94m/p)
- IPC Chip CPH: 27,500 (vs. GI-14D: 21,700) for 1 Brd
- IPC IC CPH: 27,500 vs. (GI-14D: 10,500) for 1 Brd
- Placement force: 2.5kg (vs. 1kg GI-14D)
- New 48 Hole Nozzle Changer for odd-form
- 55um(Chip)/45um(IC) at 1.33 Cpk
- 8mm Inputs: 128(DL) (vs. GI-14D: 120 (DL))
- Tray Inputs: 1 or 2 PTFs (56 / 116 Jedec Trays)
- Std PCB Size: 508mm(l) x 508mm(w)
- Opt Long PCB Kit: 1016mm(l) / 635mm(l)

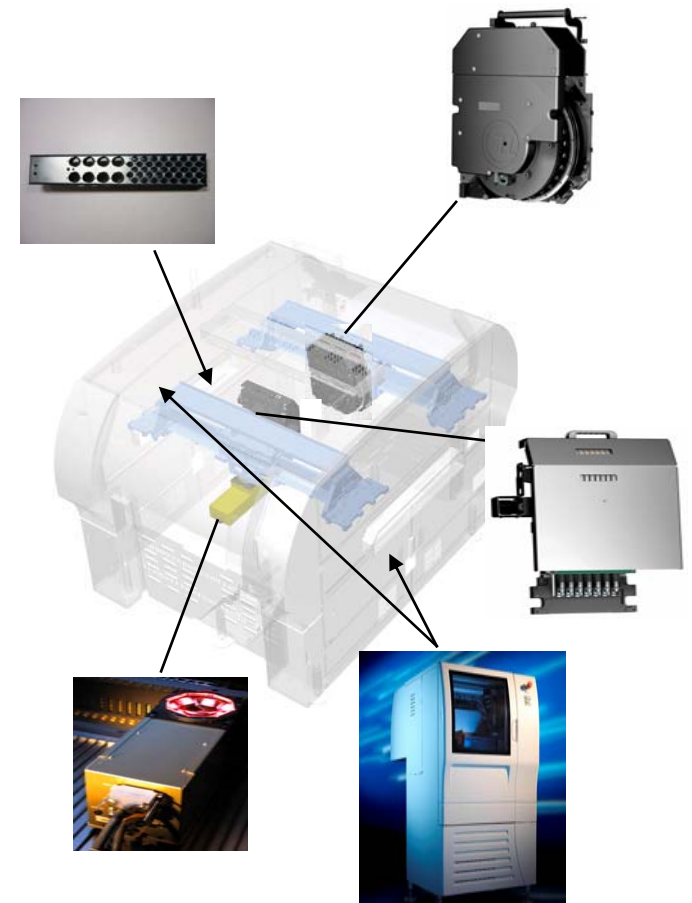

Genesis GX-37D: IPC 9850 27.5kCph

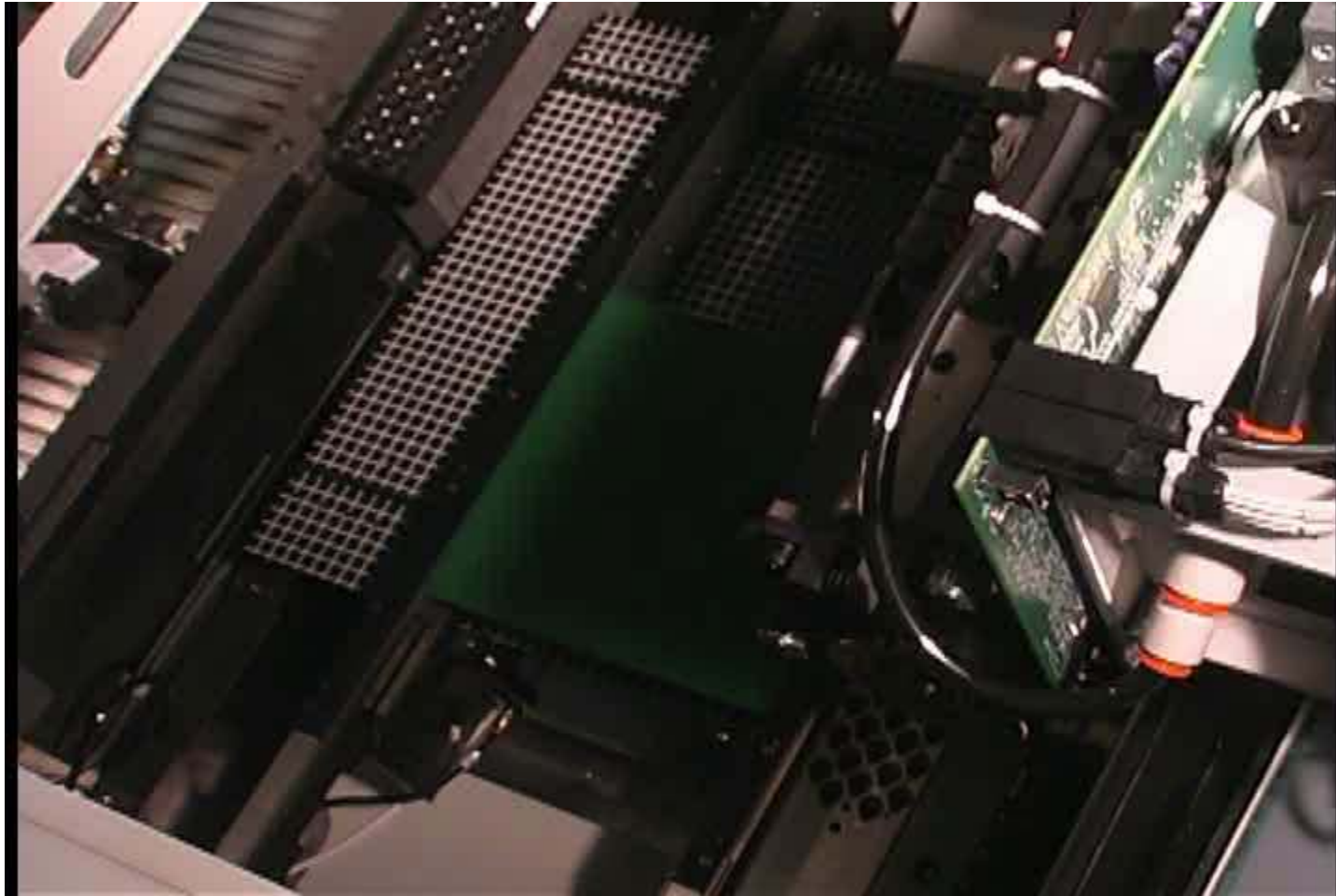

Basis of All Platforms

Base Frame

- Single beam and Dual beam series size consistent with Advantis and GSM product line
- Torsionally stiff with ability to deliver 50um pitch/25 um ball flip chip capability
- Stable enough to deliver High Speed Chip placement at 140,000 CPH Max speeds

Linear Motor Positioning System

- Patented VRM linear motor technology
- Extremely low maintenance
- High Accuracy Dual Drive System enabling 50um Pitch / 25um ball Flip Chip capability
- High Speed for maximum performance for chip placement
- 5 year warranty on all Genesis products for X, Y and Phi(Lightning) products



Board Handling

Variety of Board Handling Options For Any Product

Staged Board Handling

- PCB Length Range: 50mm to 1016mm
- PCB Width Range: 50mm to 508mm
- Automatic width control based on programmed board parameters
- Reduces transfer time by buffering one board in the lane while another is being populated
- Can transfer right-to-left or left-to-right
- Pass through mode
- 3mm edge clearance

Thin Board Kit – Supports boards down to .1mm (.0037 in) thick

Heavy Board Kit – Supports up to 7lb boards

Board Support – Host of options to minimize the effects of board warp, sag, and or flex

- Removable Pins
- Foam Finger Blocks
- Adjustable Compliant Board Pins

[Board Shuffle Video](#)

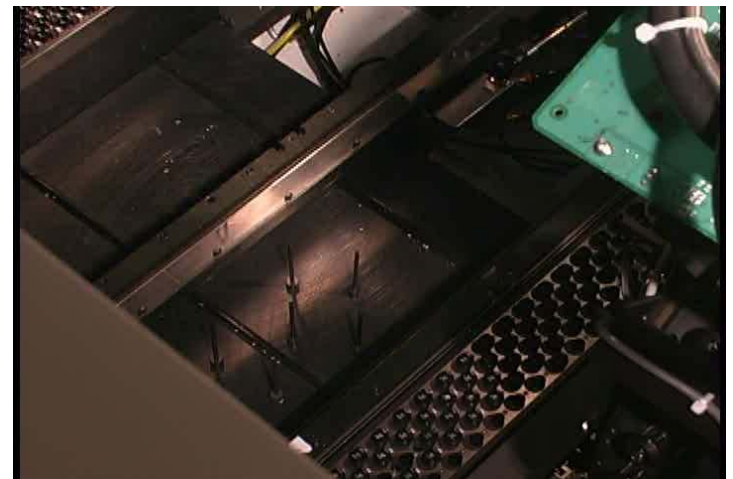

Lightning Head Technology

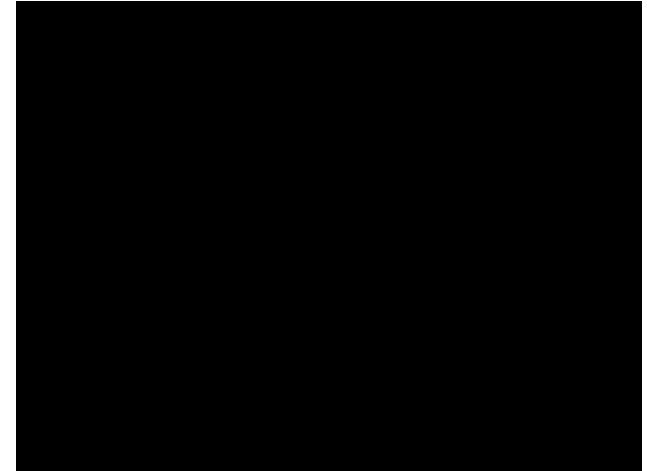
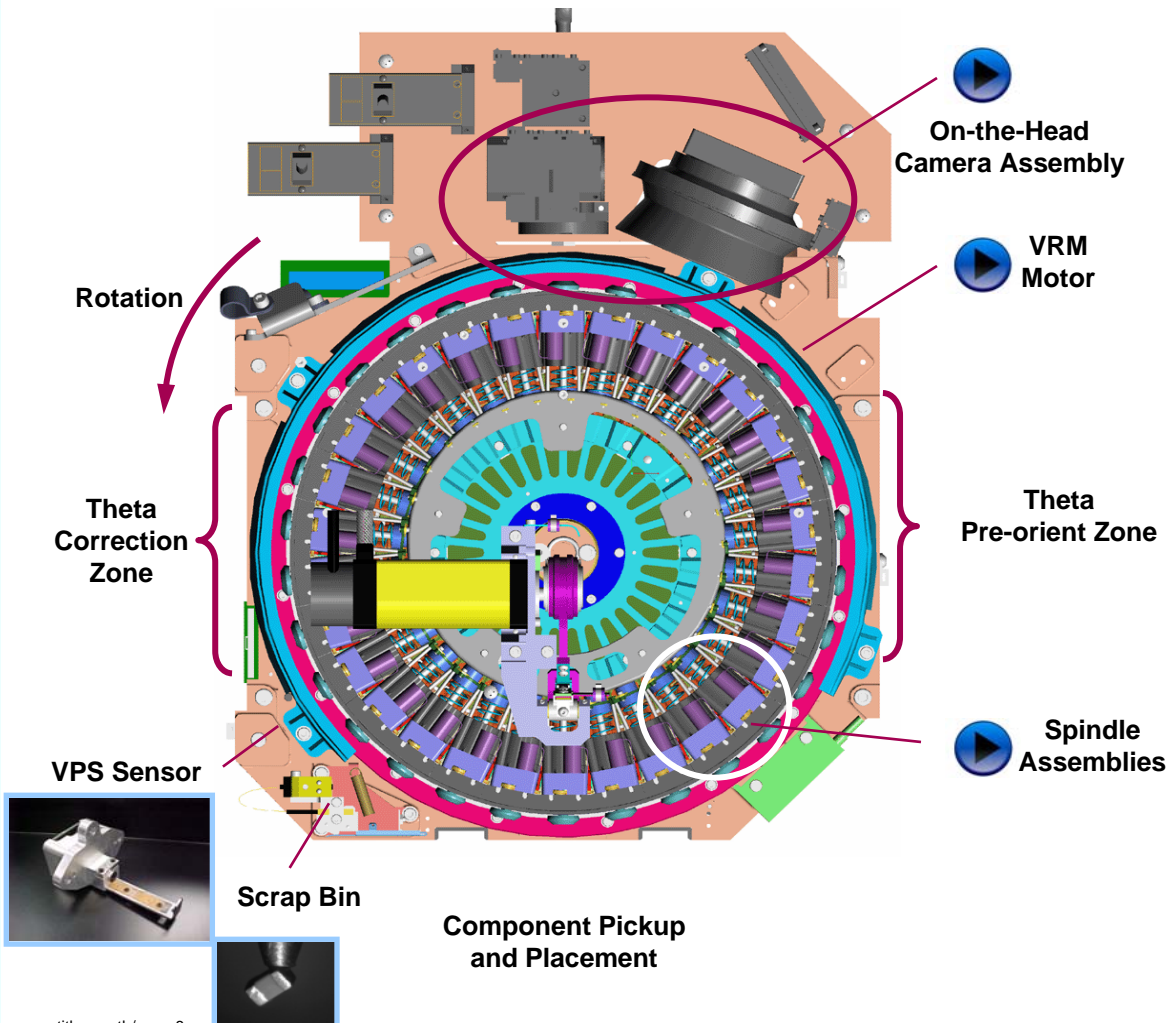

01005 qualified @ .15mm spacing



Lightning Head On-the-Head Camera Assembly

Function – Lightning Head Component Centering, Component Inspection, Nozzle Inspection

Standard Narrow Field of View (NFOV) – .55 mil/pixel

Optional Wide Field of View (WFOV) – .94 or 2.8 mil/pixel

On-the-Head Cameras

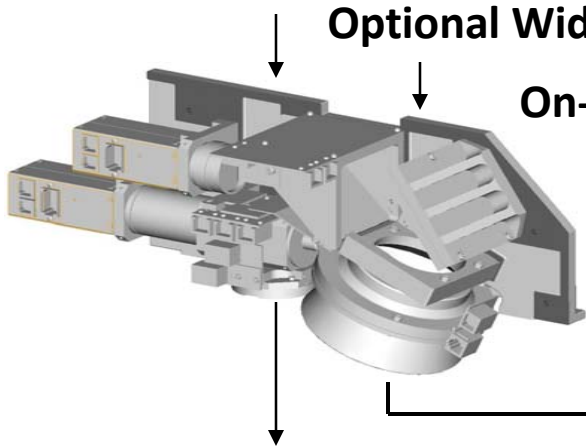

- Available in 3 different Magnifications
- On-The-Fly vision for parts within FOV
- Independent or Collective Illumination Angles: front, side, and on-axis
- 8 Programmable light intensity levels per angle
- Simple Illumination Calibration to assure consistent lighting over time

.55MPP NFOV
01005s –
12mm x 12mm
.1mm min pitch
.06mm min Ball Dia

Active: Semiconductor
Passive: <01005



Optional .94MPP
WFOV
0201s –
20mm x 20mm
.212mm min pitch
.118mm in Ball Dia

Active: Mobile uBGA
Passive: 0201

Optional 2.8MPP
WFOV
1005s –
30mm x 30mm
.51mm min pitch
.29mm min Ball Dia

Active: Server Large BGA
Passive: 0402

Vertical Part Sensor – Lower DPM

Concept of Operation - Summary

- Acquisition: Vertical Part CCD Sensing acquires a profile image of the Lightning Nozzle (Pre-Pick), or Component (Pre-Place)
- Process: Image is processed to determine if the component is properly positioned on the spindle for placement and Inspect Nozzle for Proper Height (Damage / Contamination)
- Analysis: Accept or reject the component or nozzle based on data provided in the Component or Nozzle Database

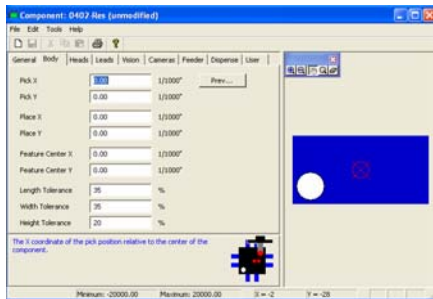
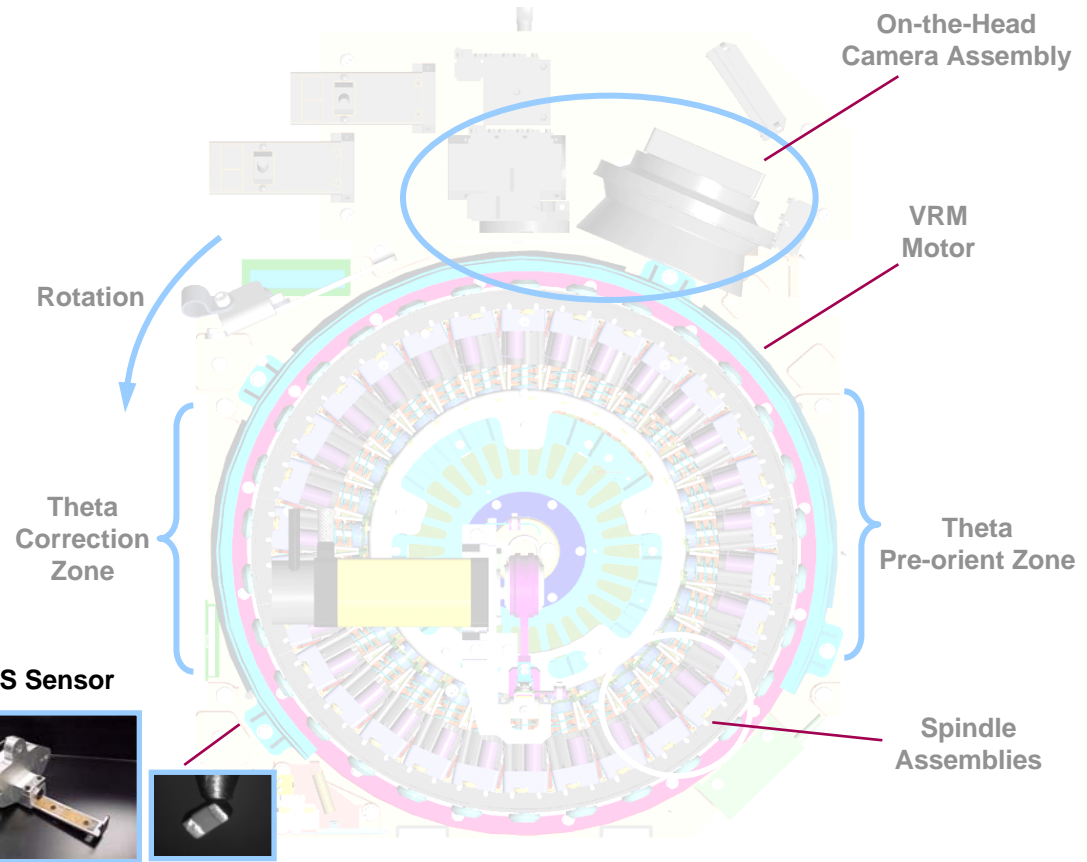

VPS Sensor



Feature	Component Range
Absence/Presence Check	01005 – 30mm sq, Up to 6mm tall
Component Height Measurement	01005 – 0603, Up to 1.25mm tall
Nozzle Seating Verification	Std Nozzles
Post Pick Inspect (absence/presence)	All component sizes

Minimize Downtime & Maintain w/ Confidence

Low maintenance requirements for minimal downtime with offline spindle tester

- **Lightning head maintenance**
 - Exchange a spindle in less than 5 minutes
 - Test Spindle with Spindle tester and perform 22 tests in less than 35 seconds
 - PM & Repair Spindle
 - Test before putting back into operation with confidence

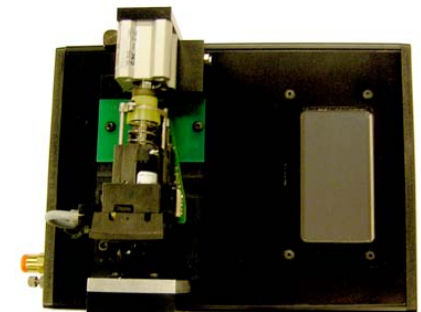

MAIN

EXIT

Lightning Head - Spindle Calibration

Lightning head Spindle Replacement Process (SRP) gets you back into full production in roughly 2 minutes.

When combining wizard style software functionality with the SRP nozzle, spindle calibration becomes a quick and hands-free operation:

- User selects spindle replacement process at the machine
- User selects head and spindle number from GUI
- Machine automatically picks up SRP nozzle
- Machine calibrates spindle
- Drops SRP nozzle back into changer
- Resume production

35% Improvement in pick PPM



InLine7 Head

Component Range

- 0603mm (0201) - 55mm x 55mm, 25mm tall
- 7 spindle head assures maximum efficiency by carrying 7 mid-sized parts to the board (up to 11mm) before having to take less as part size grows
- Low Maintenance: No pin mirrors, No OTHC, No Mirror Clutch
- High Accuracy: 60um(chips) / 45um(IC) at 1.33 Cpk



Small Part Handling Improvements

- Auto Pocket teach for InLine7 including managing substituting HP Gold Plus vs older vintage feeders

Odd-form Handling Improvements

- New Large bore Nozzle changer enables 8 large bore hole (gripper/vac) plus 40 std IL7 nozzles
- All IL7 spindles capable of 2.5kg force, expanded force capability – coming soon!



Odd Form Placement

Odd Form Nozzle Solutions – Customized For Any Application

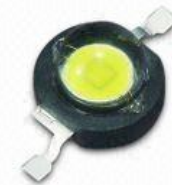
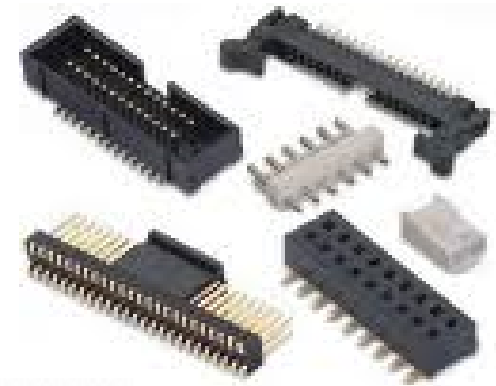
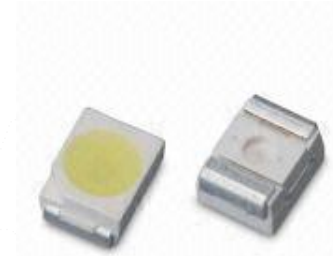

Upward Looking Camera Assembly

Function – InLine7/4 Head Component Centering, Component Inspection



Magellan Upward Looking Cameras – Non Lightning Heads

- Choose .55 MPP, .94 MPP, or 2.3 MPP Magnification Options
- On-The-Fly vision
- Overall Range: 01005's – 55mm square with single field of view
- Multiple Field of Views imaging when components exceed the FOV
- Independent or Collective Illumination Angles: front, side, and on-axis
- 8 Programmable light intensity levels per angle
- Simple Illumination Calibration to assure consistent lighting over time

.55MPP ULC
01005s –
12mm x 12mm
.1mm min pitch
.06mm min Ball Dia

Active: Semiconductor
Passive: <01005



.94MPP ULC
0201s –
20mm x 20mm
.212mm min pitch
.118mm in Ball Dia

Active: Mobile uBGA
Passive: 0201

2.3MPP ULC
1005s –
55mm x 55mm
.526mm min pitch
.292mm min Ball Dia

Active: Server BGA Sockets
Passive: 0402

GX-37D Part Range w/ .94 WFOV OTHC

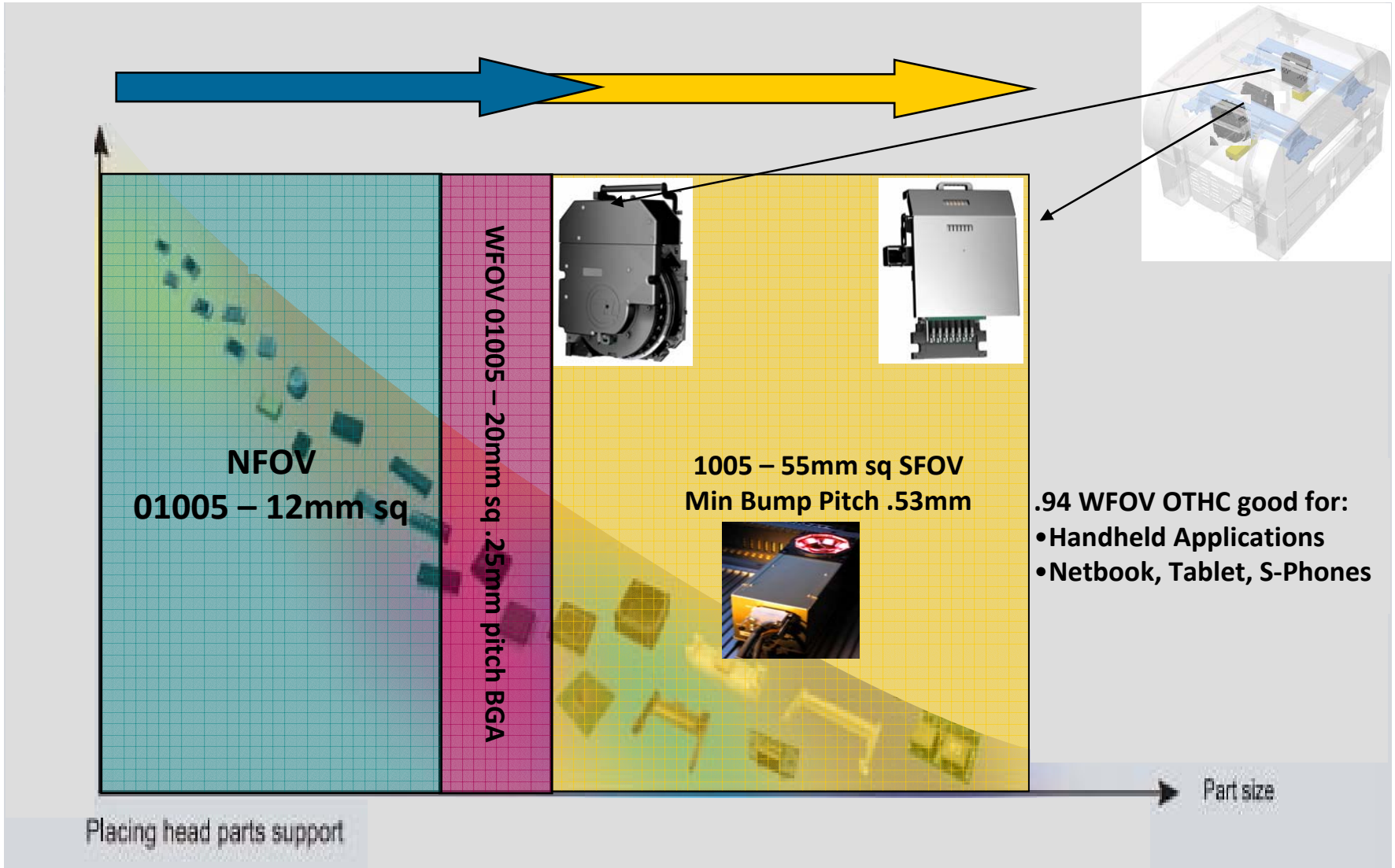

GX-37D Part Range w/ 2.8 WFOV OTHC

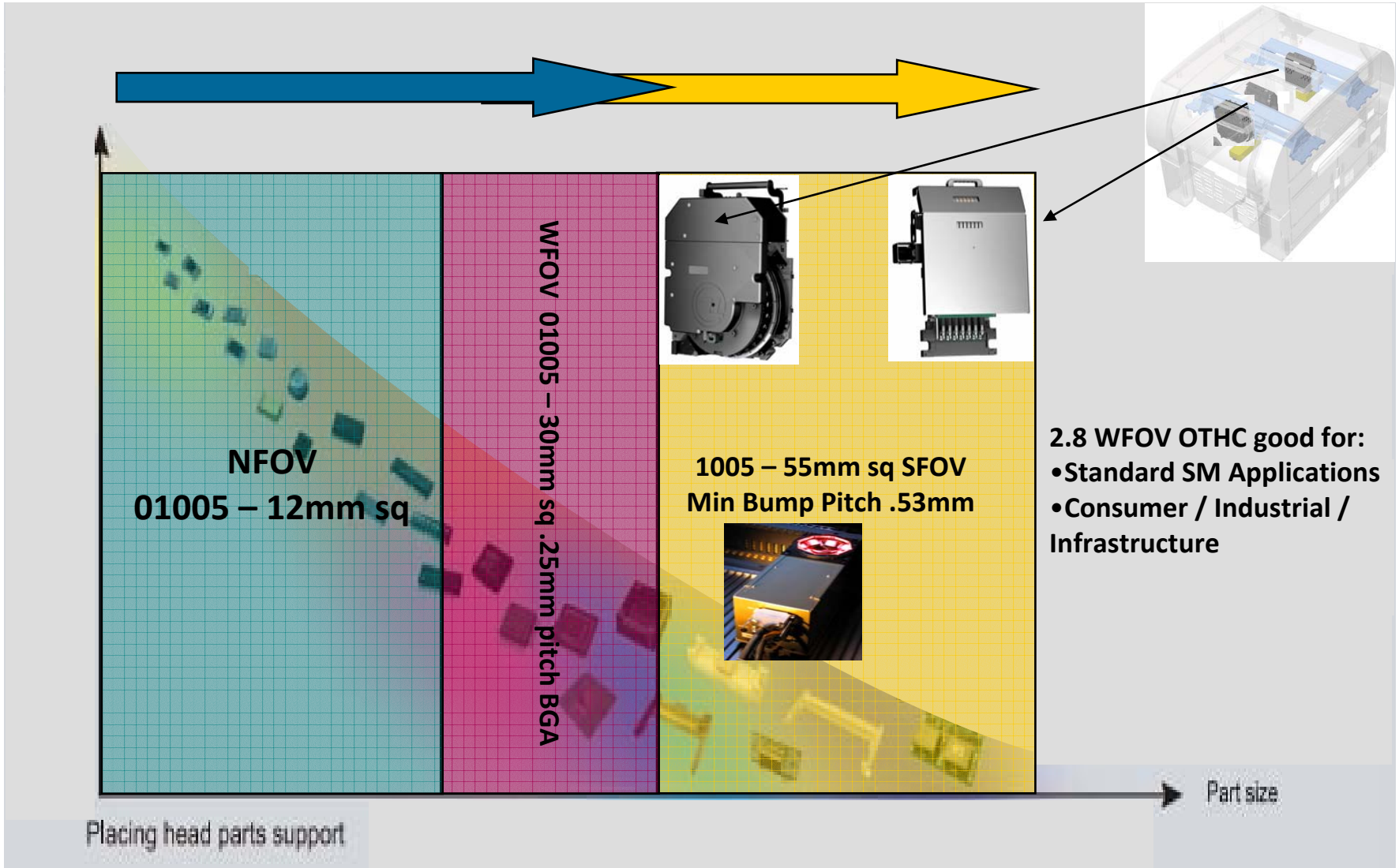

Genesis GX-37D Versatility & Efficiency

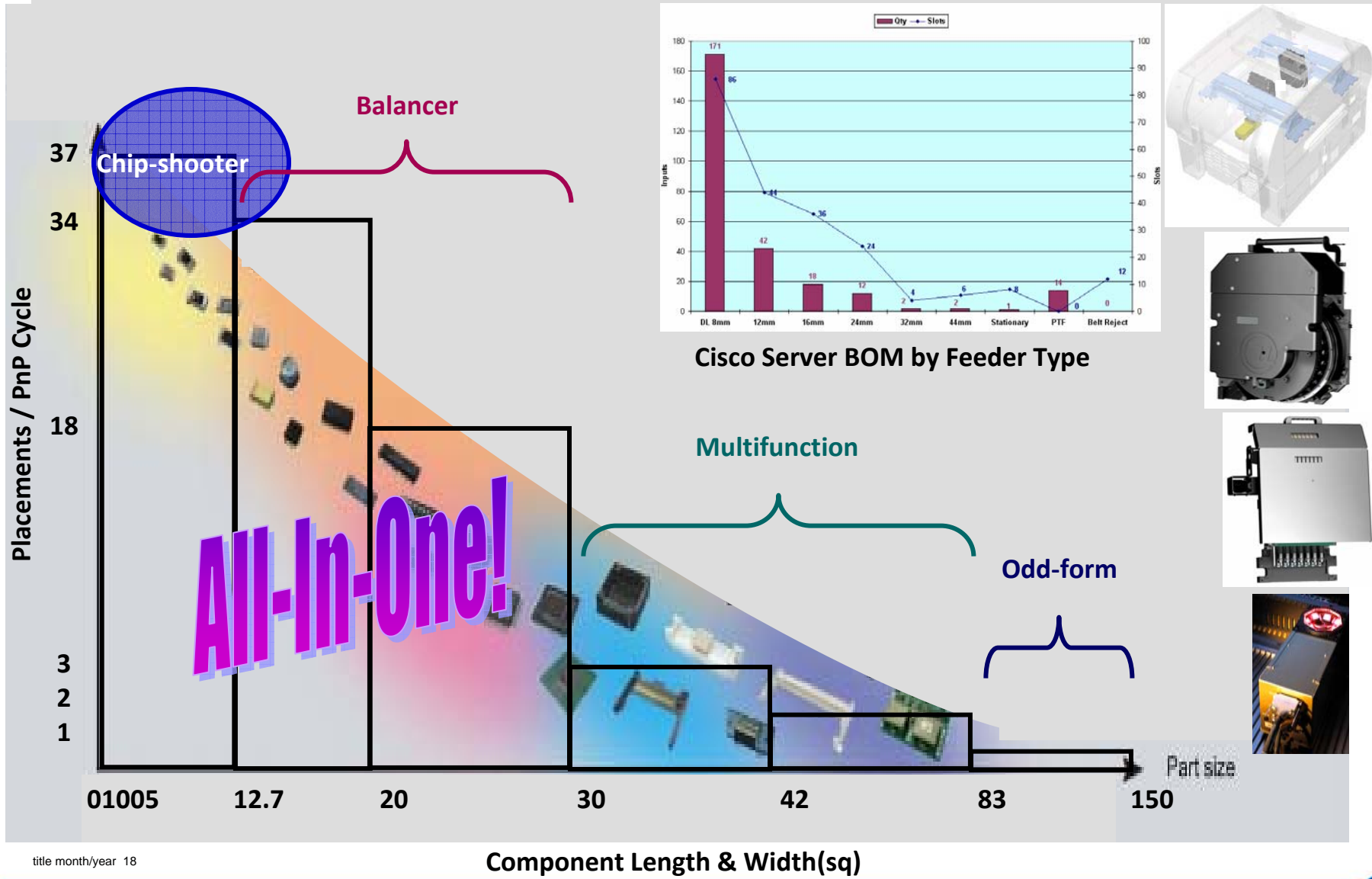

Feeder Interface

PrecisionPro™ Feeder Interface

Universal Precision Pro Feeder interface enables the serial id, cycle counts, and feeder specific data to be leveraged. The PrecisionPro feeder interface incorporates the following features:

- 3-Point registration for improved pick performance.
- Provides identification of incorrect feeder pitch and/or width mounted
- 42V DC drive voltage for faster index rate and/or higher torque. .
- Self-ID control of PrecisionPro tape feeders with serial number, cycle count tracking, pitch and width setting, and the ability to support multiple tape inputs in a single slot
- Support for four 18-slot modular feeder banks
- Support for changeable feeder banks



Feeders – Tape, Tray, Tube

High Performance Gold Plus (Continuous Splice)

- Splice Compatible
- Dual Lane 8mm
- Single Lane 8mm – 88mm
- Supports auto-validation



Tape feeders up to 88mm do not need to be removed from the machine for removal of Mylar

Multi-Tube Feeder

- 40mm – 50mm

Component Reject Station

- Allows for collection of reject components

Tray Feeders

- Platform Tray Feeder (PTF) – Supports Validation
- Direct Tray Feeder (DTF) – Supports Validation
- Stationary Matrix Tray
- SMA Tray Feeder



Dual PTF Option

Decrease Changeover / Increase Throughput

- Leverage Common Tray Setup to minimize X-over events
- Autovalidation on all PTFs to eliminate operator interaction and reduce down time
- Set up next job while running while from other PTF
- In cases with high volume of PTF parts, use both PTFs on same product to reduce cycle time
- Run in alternate mode and replenish one PTF while running from the other
- Both PTF belts mount between the rails in the front (Right Front and Left Front) and consume no tape feeder space (maintain 4 full banks)

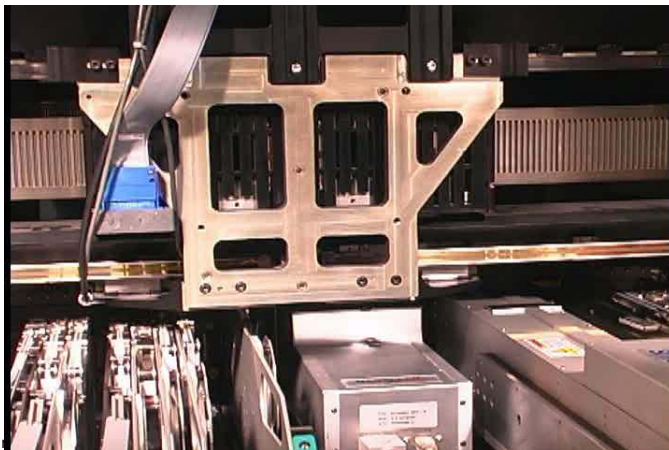
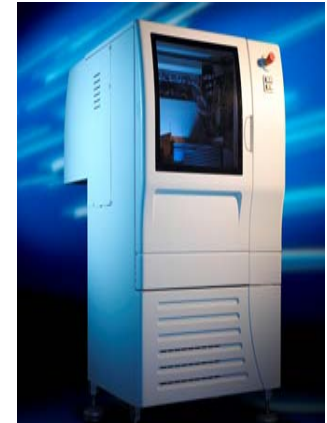

Benefits of Dual Platform Tray Feeder

Tray AutoValidation	95% Improvement Eliminates operator intervention @ x-over
Changeover Reduction	50% fewer operator events 25% reduction in overall time(xover prod)
Cycle Time Reduction	30% reduction in cycle time 13% improvement in \$/cph

Feeder Banks and Accessories

Removable Feeder Banks

The Genesis platform provides removable bank options. While one removable bank is being utilized in production on the machine, an offline removable bank can be setup/validated for the next job. The feeder bank change option reduces changeover time by swapping up to 18 feeders at a time by one operator. Feeder bank change requires at least one feeder bank change cart, and one docking module for a given feeder bank



Docking Module

A docking module is required to enable feeder bank change for any particular feeder bank location. Any combination of the four quadrants may be fitted with docking modules.

Feeder Bank Cart

The rolling feeder bank change cart option is used for removable feeder bank installation, removal, or transport. .



Feeder Load Station (Machine Mounted)

This self contained, powered station is used to load and index PrecisionPro, Gold, and Gold Plus feeders. It increases utilization and reduces production delays associated with feeder replenishment since feeders are easily prepared offline right at the machine. Up to two Feeder Load Stations can be mounted to each Genesis Platform in the left front and right rear feeder banks.

Platform Software

Universal's UPS + Software Interface

Universal's UPS+ software runs on Microsoft Windows XP operating system. It provides state-of-the-art programming, operation, and diagnostic tools for use within the Genesis Platform. This software is the same software found on all Genesis platforms. The following is a list of just a few UPS+ features

- Touch screen interface
- Common product editor across all machines
- Common component database across all machines
- Common user interface across all machines
- Dynamic Online help file
- Two levels of operation
 - Operator
 - Password protected Administrator
- Board/Cycle counts
- Machine Status – displays operation state
- Error recovery (includes recommended steps to resolve)
- Detailed event messages

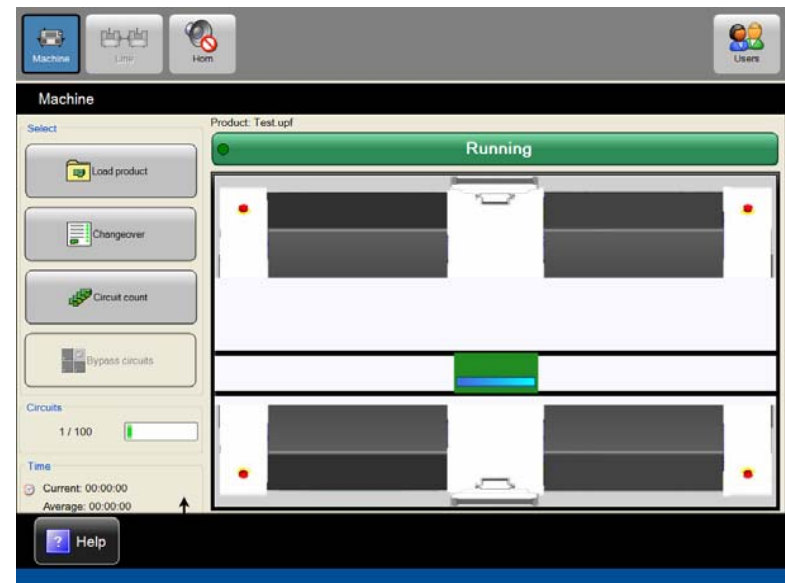

Platform Software – Error Recovery

UPS + Software Error Recovery

Universal’s UPS+ software contains error recovery screens for nearly every production time event that requires the operator’s attention. Each error recovery screen comes complete with a list of recommended steps to resolve the issue. The following lists a few of the error recovery screens displayed in UPS+:

- **Nozzle Tip Centering** – identifies incorrect nozzles on the lightning head before production begins
- **Board Transfer** – graphical display of where the error occurred in the platform and how to resolve
- **Wrong pitch/width** – displays any discrepancies between programmed feeder and the actual feeder mounted on the machine – also displays the slot location
- **Feeder Error Recovery** – displays location of exhausted feeder (s) – also signifies if validation is required if applicable
- **Incorrect Component** – displays if the wrong component was mounted
- **Auto Spindle Bypass** - machine will automatically bypass a spindle when configured PPM values are not achieved
- **Nozzle Contamination** – If a contaminated nozzle is detected on the lightning head, will automatically exchange with nozzle in changer if available

Slot	Track	Component	Reachable
10	1	603-CAP	Yes

↓

↑

+
Other actions

OK

Platform Software – NPI

UPS + Software New Product Introduction (NPI)

Supplied with every Genesis Platform machine, the NPI software package provides the following benefits to not only New Product Introduction and First Article Build, but to everyday production issues regardless of the manufacturing environment:

- **Feeder Inspection** – provides the ability to select single or multiple feeders and update the feeder (s) pick location and/or orientation through the use of a graphical overlay. Also allows the user to index the feeder directly through the screen helping to ensure there are parts available for pick.
- **Fiducial Inspect** – provides the ability to update fiducial locations and/or programmed features. Uses the same fiducial find algorithm as production to ensure fiducials will be found.
- **Pre-placement Inspection** – allows X,Y, and Theta to be updated through a graphical overlay on the screen. Also provides the ability to update all like components locations simultaneously.
- **Circuit Offset Inspection** – can verify or modify fiducial and/or component locations on a per circuit basis. Also provides the ability to edit location and/or rotation of offsets.
- **Board Population** – during population, provides a direct link to component database that allows the component information (i.e., dimensions, vision settings, etc) to be updated. Users can edit component definitions and re-inspect to ensure settings will pass vision inspection.
- **Post Placement Inspection** – used to verify placement and orientation after board has been populated.

Dimensions

Dimensions Software Suite

The complete Genesis Series II solution includes a host of optional software packages that are identified under the Dimensions portfolio. Dimension software packages provide functionality such as offline product creation and optimization, offline changeover preparation, traceability, and performance monitoring. The following Dimensions software package are available to compliment the Genesis portfolio:

Dimensions Programming and Optimization

Offline network capable software that allows for CAD import, part data management, optimization and balancing, and family setup creation.

Line Manager

Line Manager software provides offline changeover capability, low parts warning, traceability, flexible setup, and other tools designed to decrease changeover, increase throughput, and help manage inventory.

Linechart

Linechart graphically displays line data for six key performance indicators. Statistical information can be included on charts and reports can be generated and printed directly.



Low Cost of Adoption

- **Same footprint as Genesis, Advantis and GSM Platforms**
 - 1.67m x 2.2m
- **Feeders**
 - Tape Feeders: HP Gold / Gold +, Green, Multipitch
 - Tray Feeders: PTF /DTF(upgrade may be required)
 - Tube Feeders
 - Odd-form Feeders
- **Feeder Peripherals**
 - Removable banks (may require upgrade kit)
 - Feeder Carts
 - Feeder Setup Stations
- **Nozzles**
 - Lightning, FlexJet 2/3 or InLine7 nozzles
- **Tools**
 - Leverage many spare parts & set up tools
- **Programming**
 - Leverage Database definitions & programs to ease your transition to higher productivity

GX-37D: Solution for Multiple Applications

- **Increase High/Mid Volume Line Sales: Complex Infrastructure, Consumer, Auto & Industrial**
 - Today: GC-120+GC-30+GX-11S(85kcph) or GC-120 + GI-14D(72kcph)
 - 2012: GC-120 + GX-37D(82kcph + less pwr/air/operators)

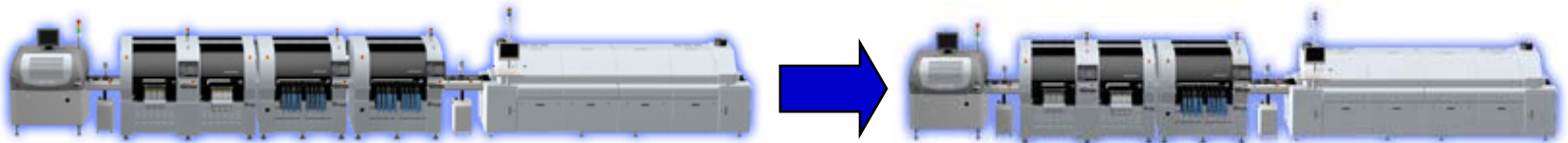

- **High Speed Multipurpose Placer(Replace Turret, Add as Balancer, Replace MF)**
 - **Chipshooter** replacement for CP, MV2, MSR/MSH, HSP, S20/25
 - **Balancer** – perfect balancer between existing Chip Placer and MF
 - 2-3x's faster than **traditional MF**

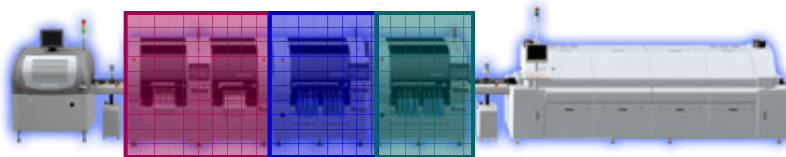

- **All-In-One(Lab/Prototype Solution) vs GC-30 + GX-11S SC**
 - Semi(SiP) – ASE, RFMD, TI
 - Memory(Flash & Thumb drive) – Kingston, Transcend
 - Effectively Handle Applications with up to 4+:1 Passive to active ratio

Genesis GX-37D: Most Powerful MF Available

- **High Efficiency**
 - Chips up to 11mm: 37 components per trip
 - Up to 20mm sq : 34 components per trip
 - Up to 30mm sq: 18 components per trip
 - High CPH/m sq.: 7,447(IPC Chip)
- **High Speed(48kcph Max)**
 - IPC: 2.5kcph(chip)/(IC) Single Board
 - Typ: 23kcph(chip)/18kcph(IC)
- **Flexibility**
 - 01005s up to 150mm long connectors
 - 25mm tall parts over 25mm tall parts
 - Up to 1016mm x 508 PCB Size
- **Odd-form Capable**
 - Auto Odd-form gripper and vacuum nozzles supported(8 holes)
 - Up to 2.5kg placement force
- **Low Cost of Switching**
 - Leverage Genesis and Advantis feeders & peripherals
- **High Capacity**
 - Up to 128 8mm inputs via DL fdr
 - Up to 116 tray fed parts while supporting up to 128 8mm inputs
 - Support for tape, track, tube, odd-form, 3rd party
- **Self-Sufficient**
 - Auto-feeder teach
 - Auto-nozzle bypass
 - Auto-spindle bypass
- **NPI Ready**
 - Import and create products offline or at machine
 - NPI tools to prototype at machine with zero component loss
 - Offline setup tools to set up and validate setups offline with no revalidation during changeover
 - Ability to use optimized programs or insert feeders in available slots for quick prototyping